

## My Miss Baker®: technical data

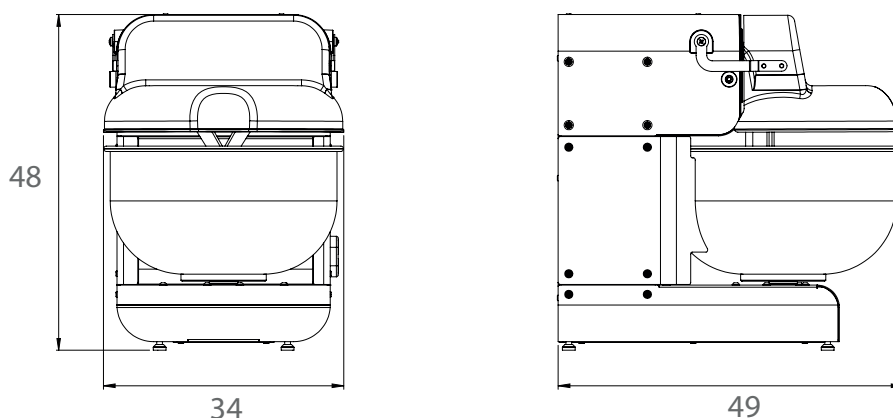

Dimensioni di massima in cm della My Miss Baker®

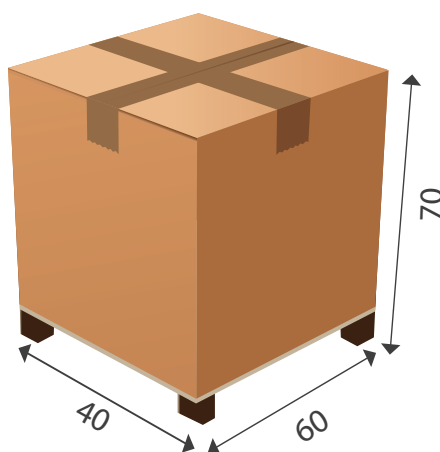

<b>My Miss Baker®</b>	
Flour capacity	0,3 - 1,8 kg
Kneading capacity	0,5 - 3 kg
Bowl capacity	10 lt
Dimensions of bowl	Ø 32 - h 18
Voltage	230 V single-phase
Power	250 W
Speed of the arms	42 strokes/min
Kneading machine dimensions <small>LxPxH (cm)</small>	33x49x48
Dimensions with packaging <small>LxPxH (cm)</small>	40x60x70
Kneading machine weight / Weight with packaging	28 kg / 39 kg
Code	MY0323010